

TeleVue®-NP101is Operating Guide

540mm f/5.4 IMAGING SYSTEM 4-ELEMENT APO REFRACTOR

Thank you for purchasing the Tele Vue-NP101is. It has been our pleasure to craft this fine instrument for you. Over forty years ago, Al Nagler took Petzval's portrait lens concept using widely spaced doublets, and patented a fast telescope design version for the purpose of testing eyepieces. The 5" f/4 MPT (Multi-Purpose Telescope) with its fast speed, wide and flat field, led to a series of continuous improvements, primarily in color correction. The "Halley Commemorative," 4" f/5.5 Renaissance started the parade where more advanced glasses including special dispersion, fluorite and fluorite substitute glasses brought steady improvements. The 4" f/5 Genesis employed fluorite in the rear doublet and the f/5.4 SDF and subsequent Tele Vue-101 versions brought us closer to perfection. Maintaining the f/5.4 speed while reducing tube length in a totally new design with new glasses allowed virtually ideal color correction and improved field flatness in this, the ideal form culminating the 40-year refinement toward perfection with the Nagler-Petzval 101. Al's "spacewalk" dream from his 1960's NASA simulator days is yours to live.

Tele Vue's "is" designation denotes instruments capable of accepting Imaging System photographic accessories. Tele Vue has designed this series of accessories in conjunction with each optical system so you are ensured of compatibility and maximum performance. While the NP101is maintains all the visual prowess of the older NP101, the larger rear elements and larger focuser, along with a host of proprietary Imaging System accessories, also makes it ideally suited for the CCD imager.

WARNING: NEVER try to look at the sun or point the telescope toward or near the sun without professional solar observing equipment rigidly secured in front of the objective lens. When observing the sun with the proper filters, remove any finding devices such as Starbeam from the telescope. Instant and permanent



eye damage may result from viewing the sun directly, even during a solar eclipse, or when viewing through thin clouds, or when the sun is near the horizon.



Standard Features - Optical tube assembly includes: captive sliding dew shield, 2.4" focuser with 10:1 Focusmate reduction, tilt adjustment end ring, screw-on metal lens cover, 2" Accessory Adapter, Imaging System Adapter, custom hard-shell case, Allen Keys for end ring tilt adjustment.

Getting Acquainted with the Tele Vue-NP101is

1.1 Optical tube assembly



The optical tube consists of an air-spaced doublet in the front cell, which attaches to the tube via three alignment screws. (Never touch the alignment screws in the front lens cell.) The rear doublet, making up the rest of the 4-element objective, is larger in diameter than the older NP101 and provides additional illumination at the edge of the field. This benefit is especially useful for large format CCD chips which are extremely sensitive to light fall-off. The rear lens group is housed in the cell that threads between the back of the tube and the focuser. Never stick any long objects into the focuser or you could hit the rear-most lens surface.

1.2 Focuser

The 2.4" output side of the NP101is focuser is designed to pass all of the field rays exiting the rear elements of the objective, as the forward end of the draw tube has a 3" internal diameter. A larger focuser, therefore, lends no additional illumination benefit.

The telescope is shipped in its "visual" configuration. The 2" Accessory Adapter sits within the 2.4" inside diameter of the drawtube. Thumb screws pass through both the drawtube and adapter to cinch a brass clamp ring around 2" accessories. With three thumb screws there is enough holding power for the heaviest of visual accessories!

The two tension screws on the top of the focuser body can be adjusted to add resistance when using heavy equipment. These tension screws tighten against a brass clamp ring, which then cinches down on the Teflon sleeve in which the draw tube slides. For photography it is not necessary to tighten

beyond the need to keep a camera stationary but we do recommend to tighten them in unison to avoid any focus shift. Note that even when sufficiently tight, the focuser knobs can still drive the draw tube.

The end ring can be adjusted (and locked) to compensate for any tilt effects seen in CCD imaging. Lock screws in the end of the draw tube tighten against either the taper of the Imaging System Adapter or brass clamp ring within the 2" Accessory Adapter.

Operation of the rack and pinion focuser is via the 10:1 ratio Focusmate on the right side or either of the 1:1 knobs. You might consider the optional Focusmate Driver for vibration-free focus control.

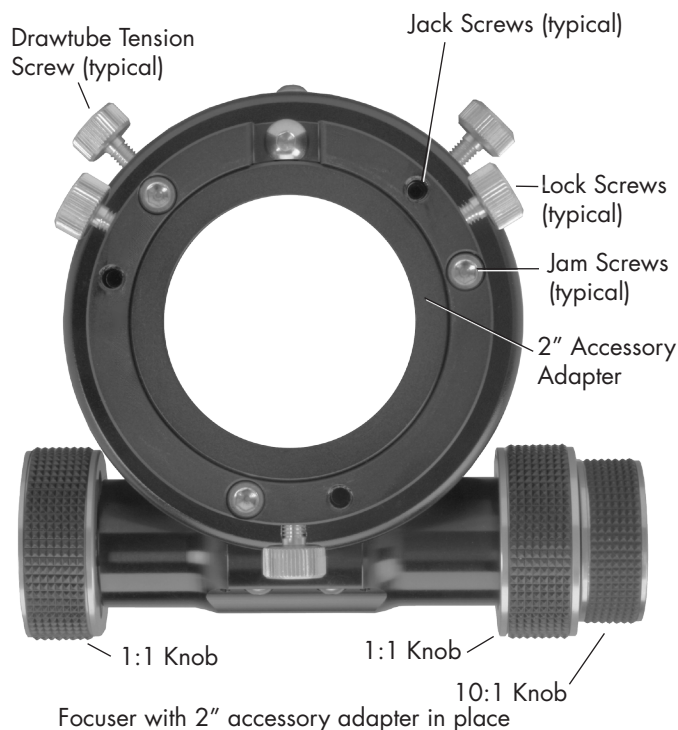



Optional Accessories Shown

1.3 Case

When opening the case, we recommend always lifting the lid while holding the handle. The lid opens a full 180° and holding the handle will give you a better grasp to insure that the lid doesn't slip out of your hand. The interior of the case was designed to store your scope with the optional Starbeam, and Focusmate Motor Driver installed. To fit the Starbeam, you may have to reposition your ring mount so that the Starbeam fits in the lid of the case between the accessory bags.

The two accessory bags within the case lid are removable. **IMPORTANT:** Whenever carrying your telescope in the case, the accessory bags must be in place as they act to hold the telescope down. Failure to do so may result in the telescope rolling into the lid of the case and damage to the telescope may occur. These bags are held in place by Velcro and can be easily lifted out. Each bag will hold a variety of accessories, so remove the foam inserts as your needs require. The right side bag is where you'll find the Imaging System Adapter. There is also a cutout for an optional Everbrite diagonal with 2" to 1 1/4" adapter inserted. Remember to zipper the bags closed before closing the case lid!



Optional Accessories Shown

2.0 Mounting Options and Set Up

The telescope tube diameter is 4". Tele Vue has two mount ring options available. The single ring (RS4-8004) and the dual ring (MRS-4011). The single ring is fine for visual and photographic use. It contains two machined grooves that accept the Starbeam (SRT-2010) unit powerfinder, the Piggy-Cam (PGC-1001) piggy back camera adapter, and Sol Searcher. The RS4-8004 is recommended for use with all Tele Vue Alt-Az mounts as it allows greater balancing opportunities than the MRS-4011.



MRS-4011 - Heavy duty tube ring set with slotted spreader bar to adjust ring spacing for a wide variety of equatorial mounts.

The dual ring MRS-4011 is best suited for critical photography and CCD imaging. It also has grooves for mount accessories. A central bar spans across the top of the two rings and permits varying the spacings between the rings in order to fit a variety of mount heads. The BPL-1098 adapter plate, on the bottom of the rings, mounts directly to Tele Vue Alt-Az mounts and is drilled to mate to a variety of mounts or mounting adapter plates. The rings contain a 1/4"-20 threaded hole to allow for mounting to third party adapter plates.

For Alt-Az mounting, Tele Vue recommends the Gibraltar-HD or Gibraltar5-HD due to their sturdy legs. You will receive the necessary attachment hardware and complete mount assembly instructions with the mount. Tele Vue makes various adapter plates for popular German equatorial mounts. Please consult your dealer.

The bottom of both mount ring systems have 1/4-20 holes to accept mounting studs or screws. The thread size in the accessory groove is #10-32. Telescope balance in both systems is achieved by unlocking the "bat handle" screws and sliding the tube fore or aft. Once repositioned, retighten the bat handle screws.

3.0 Visual Observing Set Up

In order to use the scope visually, the 2.4" diameter of the draw-tube needs to be reduced to 2". This is achieved by installing the included 2" Accessory Adapter. Note the three grooves with holes machined 120° apart. The grooves will help index the holes in the adapter to the thumb screws in the end ring. This will ease installation in the dark.

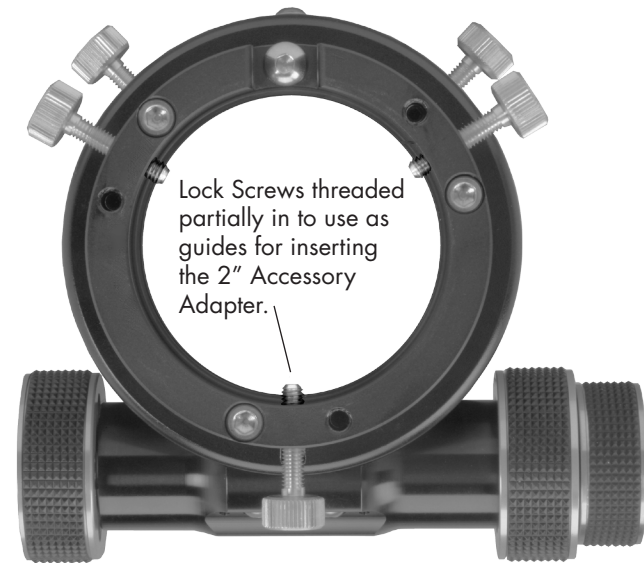

IMPORTANT CAUTION: When replacing the orange plastic plug into the 2" Accessory Adapter, push it in far enough to seat. Do not use the lock screws to clamp the plug in place as the clamp screws will distort the brass clamp ring in the 2" accessory adapter.

3.1 Eyepieces

With its highly corrected wide, flat field and fast f/ratio, the NP101 is puts eyepieces to the test. This scope demonstrates the superiority of Tele Vue eyepiece performance and, with a range of 10x to 180x (if the atmosphere allows) there is a magnification for all purposes. Atmosphere permitting, even higher power can be achieved with Barlow and Powermates. See chart at the end of this manual or call Tele Vue for recommendations. In general, we suggest choosing low and medium power eyepieces in ratios of field stop diameters. For example, factors of 1.4 or 2.0. When choosing higher power eyepieces, use ratios of magnification. (See eyepiece reference chart on last page of this manual.)

3.2 Finders

We particularly recommend using the Starbeam reflex sight (part# SRT-2010), which attaches to the Ring Mount or Tube Rings. The case has a cutout for the Starbeam. The Quick Release Universal Finder Bracket (QFM-1008) can hold a traditional 50mm finderscope and also attaches to the mount ring channels.



RS4-8004 - Slotted for accessories, three 1/4-20 tapped holes for attachment.

To install the 2" accessory adapter, loosen the three end ring lock screws sufficiently to remove any accessory that may be in place, but do not retract them fully into the focuser body. By allowing them to protrude into the body, they act as locators. Insert the 2" Accessory Adapter into the end of the focuser. If it does not go all the way in, rotate the adapter. When the grooves in the adapter align with the protruding screws, the adapter will seat fully into the focuser. Tighten the three screws a few turns so they enter the holes in the adapter. The lock screws will now act against the brass clamp ring in the 2" Accessory Adapter.

Slip a Tele Vue 2" Everbrite diagonal into the focuser and tighten the lock screws. You will now be able to reach focus with any Tele Vue eyepiece.

4.0 Photographic Set Up and the Tele Vue Imaging System

Tele Vue Imaging System Accessories provide solid threaded connections between components. To use these accessories requires the insertion of the Imaging System Adapter (ISA) into the focuser. You will find the ISA in the accessory compartment in the lid of the telescopes case. To install the ISA, first back off the three Lock Screws far enough to pull the 2" Accessory Adapter out from the drawtube to reveal the 2.4" diameter. Store the adapter in the accessory compartment in the case.

You will then need to back out the screws further so their ends are flush with the inside diameter of the End Ring. Insert the ISA and tighten the three Lock Screws located equidistant around the end ring.

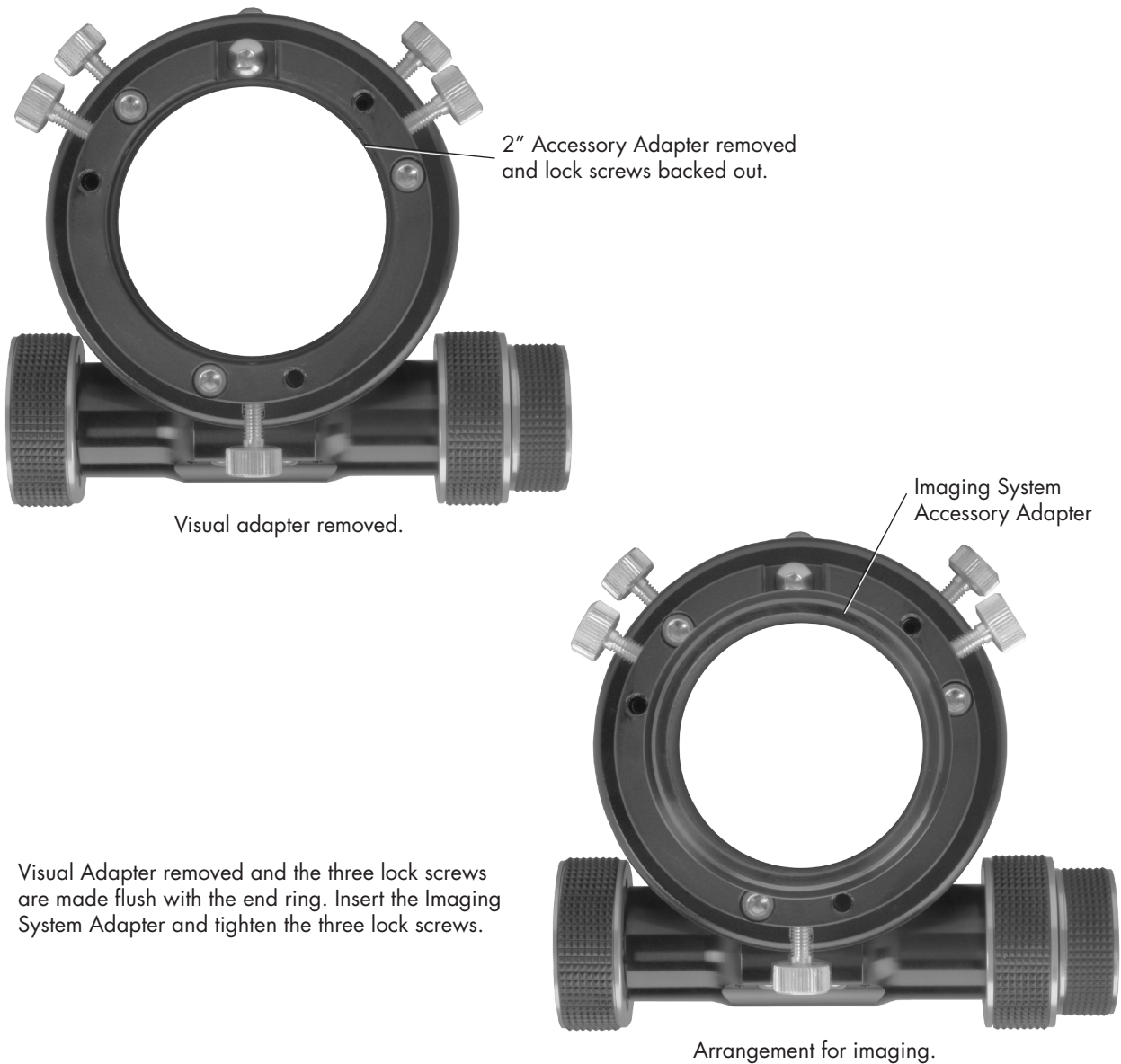

The Imaging System's threaded accessories provide a variety of options for camera adaptation and focal length variation. The goal of Tele Vue's Imaging System is to let you pursue your astrophotographic passion with ease, by providing accessories designed to work together. The following summary of parts and pictorial diagrams will help you understand each part's use and its sequence in the chain. Please note that spacing requirements of any particular camera will need to be met by the appropriate Imaging System spacer or combination of spacers.

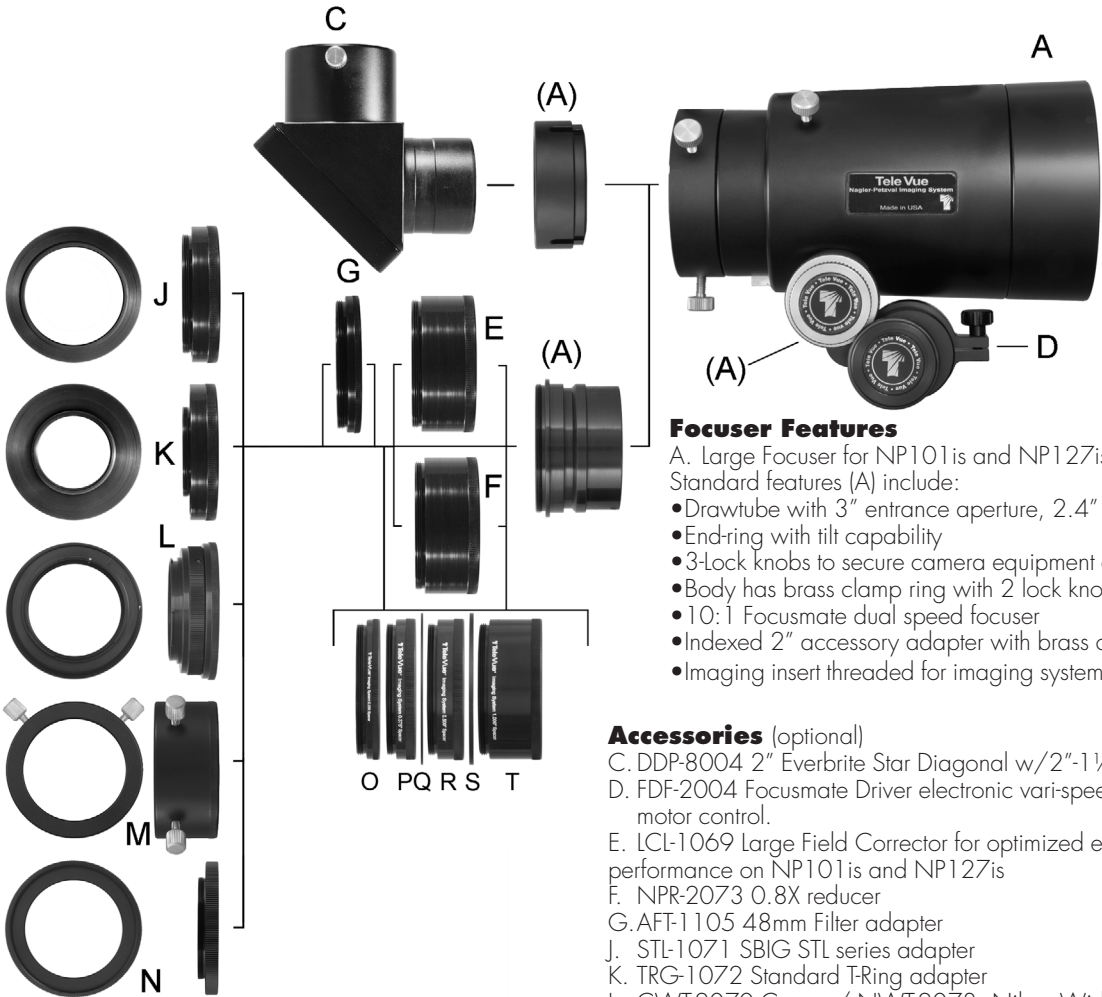

Focuser Features

- A. Large Focuser for NP101is and NP127is
 Standard features (A) include:
- Drawtube with 3" entrance aperture, 2.4" exit aperture
 - End-ring with tilt capability
 - 3-Lock knobs to secure camera equipment or 2" adapter
 - Body has brass clamp ring with 2 lock knobs
 - 10:1 Focusmate dual speed focuser
 - Indexed 2" accessory adapter with brass clamp ring
 - Imaging insert threaded for imaging system components.

Accessories (optional)

- C. DDP-8004 2" Everbrite Star Diagonal w/2"-1 1/4" Adapter
- D. FDF-2004 Focusmate Driver electronic vari-speed motor control.
- E. LCL-1069 Large Field Corrector for optimized edge performance on NP101is and NP127is
- F. NPR-2073 0.8X reducer
- G. AFT-1105 48mm Filter adapter
- J. STL-1071 SBIG STL series adapter
- K. TRG-1072 Standard T-Ring adapter
- L. CWT-2070 Canon / NWT-2073 Nikon Wide T adapter
- M. A2A-1107 2" Accessory adapter
- N. M54-1073 M54 Camera Adapter
- O. TLA-0250 0.25" long threaded extension
- P. TLB-0375 0.375" long threaded extension
- Q. TLF-0040 0.040" spacer
- R. TLC-0500 0.500" long threaded extension
- S. TLG-0080 0.080" spacer
- T. TLD-1000 1.000" long threaded extension

LCL-1069 Large Field Corrector

- Optimizes edge of field performance. Recommended for 35mm CCDs (43mm diagonal) and larger plus cameras with pixel sizes < 6µm.

NPR-2073 – 0.8x Reducer for NP and NPis series telescopes

- Designed to enlarge the field of all NP scopes for up to full-frame (43mm diagonal) imaging and is a replacement for the previous NPR-1073 0.8x for up to APS size (27mm diagonal) formats
- Constructed to fit both standard 2" focuser NP scopes (RAD-1074 required) and the threaded "NPis" Accessories on the input end. Requires additional Imaging System rings to connect to imaging train.

STL-1071 – SBIG STL series camera adapter

- This adapter is sized to thread directly onto the STL series cameras and mates with I.S. Accessories.

TRG-1072 – Standard T-ring adapter

- This is the most restrictive of adapters in terms of vignetting as it has the smallest inside diameter. Recommended for use with APS size or smaller formats.

CWT-2070 – Canon / NWT-2073 – Nikon Wide T Adapter

- Mates Canon EOS or Nikon F-mount body with Imaging System Accessories.
- Eliminates the inner portion of Canon and Nikon T-rings to provide a larger diameter opening for reduced vignetting.

A2A-1107 – 2" Accessory Adapter

- Use for cameras with 2" nose-piece or any other 2" accessory.
- Dual thumb-screws and clamp ring for positive locking.

M54-1073 M54 Camera Adapter

- Used for full-frame cameras with M54 x 0.75mm threads.
- Can also connect to filter wheels with M54 threads.

AFT-1105 – 48mm Filter adapter

- Allows use of 48mm filters in the system.
- Best if used closest to the chip to minimize any vignetting
- Adds 0.25" of spacing.

TIA-0250 – 0.250" (6.4mm) Spacer

TIB-0375 – 0.375" (9.5mm) Spacer

TIC-0500 – 0.500" (12.7mm) Spacer

TID-1000 – 1.000" (25.4mm) Spacer

TIF-0040 – 0.040" (1mm) Spacer

TIG-0080 – 0.080" (2mm) Spacer

TLS-2245 – Set of all six spacer rings.

- Threaded coupling provides the necessary distance for proper spacing of field lenses to CCD chip. Required spacers will vary depending on camera specifications. 0.040" and 0.080" rings fit between the threaded spacers.

- Black anodized aluminum with anti-reflection threads for maximum contrast.

4.1 Adjustable Position End Ring

The tilt of the End Ring is pre-set to ensure the end surface is parallel with the focal plane. If you see tilt errors in your images, the optical axis can be changed to compensate.

To determine which way to tilt the End Ring, it is necessary to focus on the part of the image that comes to focus first when racking out the focuser from its "in" position. That will permit adjusting, or "jacking," the End Ring "out" to match that focus point in other parts of the field

You will need to remove your camera equipment, including the Imaging System Adapter to adjust the tilt of the End Ring. Slightly loosen the three Jamb Screws located on the face of the End Ring with the appropriate Allen key. Then, "jack" the End Ring to the desired position using the appropriate Allen key Jack Screws. Note: when adjusting the jack screws, make very slight turns as a 1/4 turn equals a longitudinal movement of 198 microns at the screw. Tighten the Jamb Screws against the End Ring and reinstall your camera. Some trial and error imaging will be necessary, so it is best to carry out any adjustment during an imaging session.

4.2 Prime Focus

Prime focus photography involves attaching a camera, without its lens, to the telescope. In this method the telescope becomes the camera's lens. In the case of the NP101 is, it is a 540mm focal length, f/5.4 telephoto. It is the focal length of the telescope in combination with the diagonal dimension of the CCD chip or film frame that will determine the amount of field your photograph will cover. The shorter the focal length or larger the diagonal dimension, the greater the field that will be recorded.

The parts necessary for Prime Focus photography are: camera body, accessories (filter wheel /drawer, off axis guider, etc.) appropriate Imaging System adapter, Large Field Corrector or 0.8x reducer with Extension Spacers to achieve proper back focus, drawtube Extension Spacers to limit drawtube extension to approximately 0.75" (20mm), the Imaging System adapter, and telescope. See the following diagrams for a visual explanation.

Camera Setup Examples

In the examples here, spacers shown are for illustrative purposes: your spacing will be unique. For instances where accessory lenses are not used, spacers will only determine focus position and therefore are not critical.

1. Prime Focus

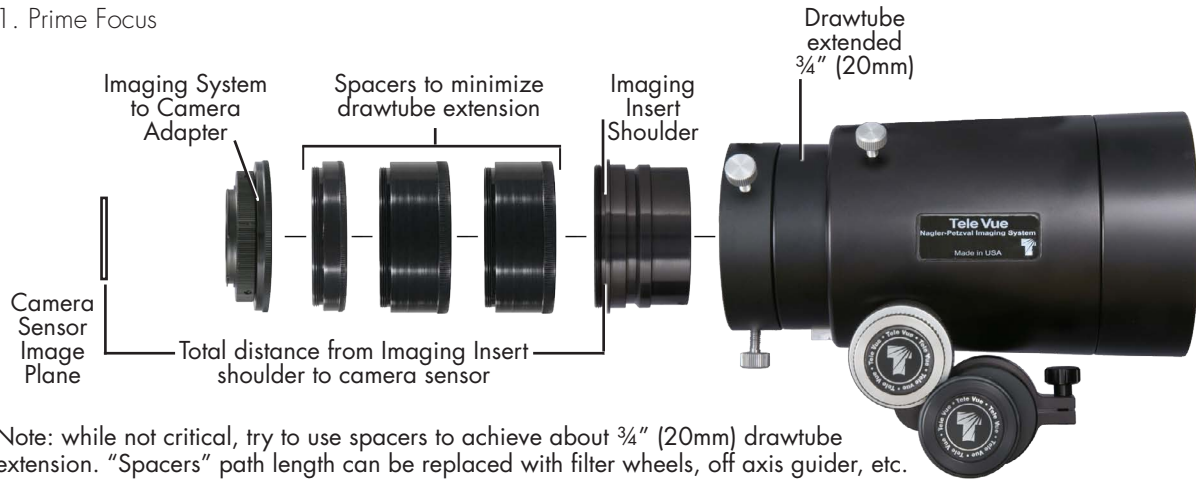

Note: while not critical, try to use spacers to achieve about $\frac{3}{4}$ " (20mm) drawtube extension. "Spacers" path length can be replaced with filter wheels, off axis guider, etc.

2. One Shot Color or DSLR Camera with 0.8X Reducer (NPR-2073)

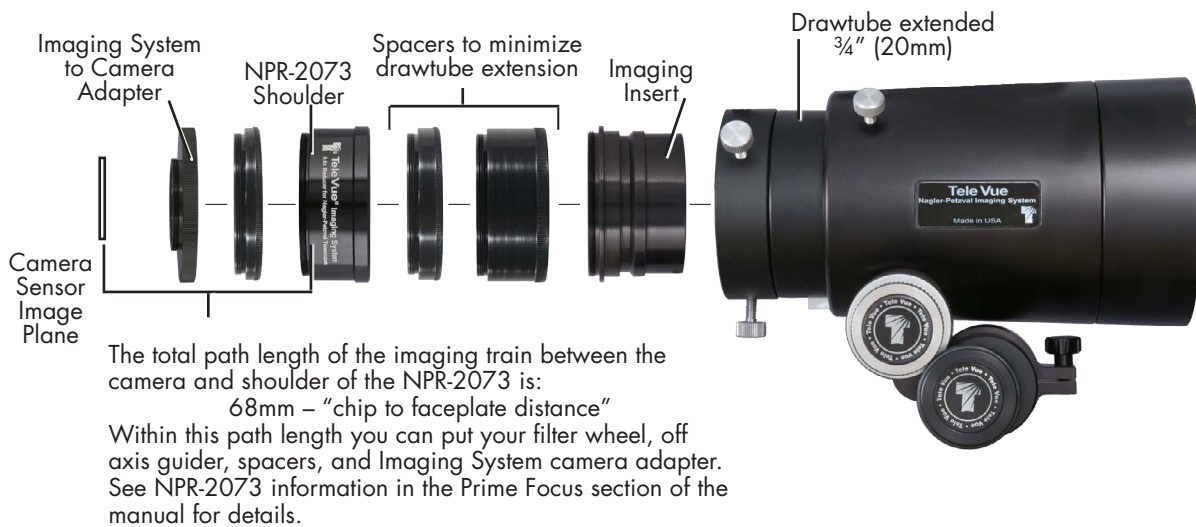

3. Full-Frame Camera with Large Field Corrector (LCL-1069)



Large Field Corrector Usage. To obtain the best edge sharpness with 35mm or larger formats or in all sensor formats when the sensor pixels are $< 6 \mu\text{m}$, you must use the Large Field Corrector (LCL-1069). For optimum performance, the distance from the base of the male thread on the camera-facing side of the LCL-1069 to the camera sensor must be **2.75"**. In order to determine how much Back Focal Length (BFL) you need to maintain between the camera face and LCL-1069, you need to know the distance from the chip to the faceplate of the camera. This should be specified in the camera's documentation; call your camera's manufacturer if it is not. Simply subtract "chip to faceplate" distance from **2.75"** to get the spacing required from the Large Field Corrector to your camera faceplate, for up to 35mm formats. If accessories such as filters wheels or off axis guiders are used, their path length must also be deducted from the **2.75"** figure. For larger formats, such as 53mm diagonal sensor, use **2.67"** instead of **2.75"**.

Since there are tolerances in all manufactured parts, it may be necessary to vary the spacing slightly from the nominally calculated value. Should your star images in the four corners look equally slightly elongated, try using the next smallest increment of threaded spacer with either the 0.040" (TLF-0040), 0.080" (TLG-0080), or both in between the threaded spacers to fine tune the image.

4.2a) 0.8x Reducer (NPR-2073) Usage. To gain more field with chips up to full-frame, use the 0.8x Reducer (NPR-2073). For One Shot Color and DSLR cameras, use a Back Focal Length (BFL) of **68mm**. In the case of imaging in full-frame monochrome with LRGB or HST palette filters, a BFL of **50mm** should be used (this includes the +1 mm shift required for a single 3mm filter). If your imaging stack exceeds **50mm** due to accessories, then use the **68mm** distance. Just subtract from either of these distances the "chip to faceplate" distance to get the spacing required from NPR-2073 to your camera faceplate. If accessories such as filters wheels or off axis guiders are used, their path length must also be deducted from the **68mm** figure. For all setups, use Extension Spacers to minimize draw tube out-travel to no more than $\frac{3}{4}$ " (20mm). See NPR-2073 instruction sheet for details.

4.2b) Special Note for ZWO Usage. ZWO instructions are standardized on producing an imaging stack with 55mm Back Focal Length using their various cameras, filter wheels, Off Axis Guiders, and adapter rings. In order to properly back space the sensor behind our optical accessories, simply subtract 55mm from our recommended spacing distance and add back 1mm for every 3mm of filter thickness. Using our 2.75" (69.85mm) spacing example for the Large Field Corrector with a 3mm filter, the math is as follows: $69.85\text{mm} - 55\text{mm} + 1\text{mm} = 15.85\text{mm}$ of additional spacing is required. Our TRG-1072 (M42x0.75mm) or M54-1073 (M54x0.75mm) adapters (6.6mm of path) will connect to the telescope end of the ZWO 55mm stack (in some cases use ZWO's M48-M42 zero path length converter). Next, simply thread on our TLB-0375 (9.5mm of path) to achieve the required path length.

Likewise, employing ZWO's 55mm stack with the 0.8x Reducer (NPR-2073), requires use of the 68mm back focus option in all cases as the 50mm option is not possible. This spacing with a 3mm thick filter requires: $68\text{mm} - 55\text{mm} + 1\text{mm} = 14\text{mm}$ more spacing. Pairing our TRG-1072 or M54-1073 (6.6mm of path) adapters with the TLA-0250 (6.4mm of path) and TLF-0400 (1 mm of path) exactly makes up that 14mm requirement.

4.2c) To gain more magnification, the 2x (PMT-2200) and 4x (PMT-4201) Powermates are recommended for best performance. Start by inserting the 2" Accessory Adapter into the end of the focuser. (Since increasing the magnification will reduce the field, the large opening provided by the Imaging System Adapter is of no benefit.) The arrangement of parts necessary is: camera with a T-ring attached, Powermate with corresponding T-ring adapter (PTR-2200 or PTR-4201) attached, 3.5" Extension Tube (X3C-0009), to make up focus travel, and telescope.

If you prefer to use the threaded I.S. adapters, you would need three 1" spacers (3x TLD-1000) plus the 2" Accessory Adapter (A2A-1107). Start by inserting the ISA into the end of the focuser. The arrangement of parts necessary is: camera with a T-ring attached, Powermate with corresponding T-ring adapter (PTR-2200 or PTR-4201) attached, 2" Accessory Adapter (A2A-1107) and three 1" spacers (3x TLD-1000) to make up focus travel, and telescope.

There are certainly a variety of ways of setting up the Tele Vue-NP101 is for photography!

5.0 ADDITIONAL ACCESSORIES

5.1) The Focusmate Driver for the NP101is (FDF-2004) electronically drives the fine focus knob of the 10:1 Focusmate in steps of approximately 0.0005" per button click. With the button depressed, the motor drives the Focusmate continuously without vibration transferred to the system. Motor speed is variable. The motor has a standard phone jack that will accept a cord of any length.

For remote focusing options, we suggest contacting Starlight Instruments or Optec for their offerings. While there may be other options available we cannot guarantee a direct fit to our pinion assembly.

5.2) The NP101is package (TVP-4058) is designed for visual use of this scope. It includes the 4" clamshell-style Ring Mount with 1/4"-20 mounting threaded holes to attach to a heavy-duty tripod or telescope mount, 2" 90° Everbrite Diagonal (99% reflection across visual spectrum) with 2" to 1 1/4" adapter, and 18.2mm DeLite eyepiece, with 20-mm eye-relief, that yields a 2° true field of view at 30x in this scope.



6.0 Caring for your NP101is

The Tele Vue-NP101is requires no special care. Treat it as you would any fine camera lens. Use the lens cap when the telescope is being stored or not in use. The captive dew shield provides protection from glare, helps protect the lens from dust or spray blown in by the wind and minimizes dew formation on the lens.

If dew forms on the lens during cold weather, it is best to use a hair dryer (on the lowest setting) to gently warm it away. A few specks of dust will have no effect on image quality and may be gently blown off with a squeeze bulb. Do not use compressed air cans to blow dust off optical surfaces.

To prevent dew formation when bringing the scope in from the cold, we advise to close the cold scope in its case before bringing it into the warm indoors. Do not open the case until the scope has come up to room temperature.

Fingerprints or oils should be cleaned off the lens surface. Though the anti-reflection coatings are durable, they can be scratched. The simplest cleaning method is to moisten a very soft, lint-free tissue, cloth, "Q-Tip" or surgical cotton with a lens or glass cleaner and working in a circular motion, gently whisk away the stain. Do not apply any solutions directly to the glass surfaces. After every cleaning stroke, use a fresh applicator. The fewer strokes the better! Any residual "film" will not affect visual performance.

Collimation of your Tele Vue-NP101is has been locked at the factory. With reasonable care it will remain aligned. However, rough handling or improper packaging for shipment can cause misalignment. **WARNING:** The button head screws in the front lens cell are filled with epoxy. Loosening these screws will cause misalignment. If necessary, contact Tele Vue for re-collimation.

Your star diagonal employs a first-surface mirror. Like all first-surface mirrors, it should be cleaned only when absolutely necessary. First blow loose dust away with a squeeze bulb. **CAUTION:** Do not clean the mirror with water or water based cleaners such as Windex or any other commercial lens cleaners; this is not a lens. All contain too much water and will leave stains. Moisten a "Q-Tip" with pure acetone, methanol or Isopropyl alcohol, reagent grade. Clean gently using only the weight of the cotton swab. Use light pressure and never rub. Slight residual stains or dust have no visible effects in observing.

The tube is powder-coated for durability and can be waxed with any nonabrasive car wax. Black anodized surfaces can be cleaned with Windex. If you have any questions about the care, operation or performance of your Tele Vue-NP101is, please call us at (845) 469-4551 from 9:30 am to 5:00 pm EST.

7.0 Warranty

Tele Vue telescopes are warranted to be free of manufacturing or workmanship defects for 5 (five) years from the date of purchase, to the original owner. Please return the warranty card as validation of your ownership and for easy identification. If your Tele Vue telescope requires warranty service, please call Tele Vue to discuss the problem, upon which you will receive a return authorization. NO RETURNS ARE ACCEPTED WITHOUT PRIOR AUTHORIZATION. A copy of your sales receipt may be requested if you have not submitted your warranty registration material.

The warranty does NOT include: collimation, defects caused by mishandling, defects of subjective nature, or coverage for any telescope purchased through an unauthorized Tele Vue dealer. However, for claims of telescopes arriving out of collimation you must contact Tele Vue Optics within 30 days from date of delivery, verifiable by sales receipt.

Warranty work will be performed at Tele Vue's discretion and may only be performed by Tele Vue Optics or Tele Vue authorized agent. The telescope must be shipped in its case with proper inner and outer packaging. Shipping and insurance charges are the purchaser's responsibility.

8.0 Specifications

Type	4-element, flat field, APO refractor, Fully Multi-Coated
Clear Aperture	4 inches (101.6mm)
Aperture Gain	211, compared to a 7mm exit pupil
Focal Length	540mm
Focal Ratio	f/5.4
Resolution (visual)	1.1 arc-sec. (Dawes Limit for a 4 inch aperture)
Resolution (photographic)	267 line pairs per mm
Magnification	10x to 270x using Tele Vue eyepieces
Field, Visual	4.9° at 10x
Focuser	2.4-inch, rack and pinion type
Diagonal	Accepts optional 2-inch 99% reflective dielectric coating, with 1 1/4" adapter
Finder	Optional Starbeam or 55mm Plössl for 10x, 4.9° field
Mounting	Optional adjustable ring mount or tube rings with 1/4-20 tapped holes for standard photographic tripods or optional Tele Vue and Vixen mounts
Weight	10.6 lbs. (tube assembly) 19 lbs. in case, 28 lbs. shipping
Length	26-inches (O.T.A. only)
Accessories	included as standard: custom fitted case, screw-on lens cover, sliding dew (glare) shield, 2" Accessory Adapter, Imaging Systems Adapter
Tube	Powder-coated aluminum

Specifications subject to change without notice.

Tele Vue recommends choosing low and medium power eyepieces in ratios of field stop diameters. For example, factors of 1.4 or 2.0. When choosing higher power eyepieces, use ratios of magnification.

Tele Vue-NP101/NP101is											
Focal Length (mm)	Type	Product Code	Apparent Field (deg)	Field Stop Dia. (mm)	Eye Relief (mm)	Weight (lb.)	Mag.	True Field (deg)	Exit Pupil (mm)	# of Elem.	Dioptrx Ready
2" Eyepieces for Wide True Fields											
55	Plössl	EPL-55.0†	50	46.0	38	1.1	9.8	4.88	10.3	4	Y
41	Panoptic	EPN-41.0	68	46.0	27	2.1	13.2	4.88	7.7	6	Y
31	Nagler 5	EN5-31.0	82	42.0	19	2.2	17.4	4.46	5.8	6	Y
35	Panoptic	EPN-35.0	68	38.7	24	1.6	15.4	4.11	6.5	6	Y
21	Ethos	ETH-21.0	100	36.2	15	2.3	25.7	3.84	3.9	-	Y
22	Nagler 4	EN4-22.0	82	31.1	19	1.5	24.5	3.30	4.1	7	Y
27	Panoptic	EPN-27.0	68	30.5	19	1.0	20.0	3.24	5.1	6	Y
17	Ethos	ETH-17.0	100	29.6	15	1.6	31.8	3.14	3.2	-	Y
24	Delos	EDL-24.0	72	29.6	22	1.2	22.5	3.14	4.5	-	Y
19	Nagler 7	EN7-19.0	82	27.1	19	1.3	28.4	2.88	3.6	-	Y
14	Nagler 7	EN7-14.0	82	20.5	19	1.2	38.6	2.18	2.6	-	Y
1¼" Eyepieces for Wide True Fields											
40	Plössl	EPL-40.0	43	27.0	28	0.4	13.5	2.87	7.5	4	Y
32	Plössl	EPL-32.0	50	27.0	22	0.4	16.9	2.87	6.0	4	Y
24	Panoptic	EPN-24.0	68	27.0	15	0.5	22.5	2.87	4.5	6	Y*
13	Ethos	ETH-13.0	100	22.3	15	1.3	41.5	2.37	2.4	-	Y
16	Nagler 5	EN5-16.0	82	22.1	10	0.4	33.8	2.35	3.0	6	N
19	Panoptic	EPO-19.0	68	21.3	13	0.4	28.4	2.26	3.6	6	Y*
25	Plössl	EAP-25.0	50	21.2	17	0.3	21.6	2.25	4.7	4	N
17.3	Delos	EDL-17.3	72	21.2	20	0.9	31.2	2.25	3.2	-	Y
18.2	DeLite	EDE-18.2	62	19.1	20	0.5	29.7	2.03	3.4	-	Y
10	Ethos	ETH-10.0	100	17.7	15	1.1	54.0	1.88	1.9	-	Y
13	Nagler 6	EN6-13.0	82	17.6	12	0.4	41.5	1.87	2.4	7	Y*
14	Delos	EDL-14.0	72	17.3	20	0.9	38.6	1.84	2.6	-	Y
20	Plössl	EAP-20.0	50	17.1	14	0.2	27.0	1.81	3.7	4	N
15	DeLite	EDE-15.0	62	16.0	20	0.5	36.0	1.70	2.8	-	Y
1¼" Eyepieces for Medium Powers											
12	Delos	EDL-12.0	72	15.0	20	0.9	45.0	1.59	2.2	-	Y
13	DeLite	EDE-13.0	62	13.8	20	0.5	41.5	1.46	2.4	-	Y
9	Nagler 7	EN7-09.0	82	13.0	19	1.2	60.0	1.38	1.7	-	Y
10	Delos	EDL-10.0	72	12.7	20	0.9	54.0	1.35	1.9	-	Y
15	Plössl	EAP-15.0	50	12.6	10	0.2	36.0	1.34	2.8	4	N
9	Nagler 6	EN6-09.0	82	12.4	12	0.4	60.0	1.32	1.7	7	Y*
11	DeLite	EDE-11.0	62	11.7	20	0.4	49.1	1.24	2.1	-	Y
9	DeLite	EDE-09.0	62	9.6	20	0.5	60.0	1.02	1.7	-	Y
11	Plössl	EAP-11.0	50	9.1	8	0.1	49.1	0.97	2.1	4	N
1¼" Eyepieces for Higher Powers											
8	Ethos	ETH-08.0	100	13.9	15	1.0	67.5	1.47	1.5	-	Y
6	Ethos	ETH-06.0	100	10.4	15	1.0	90.0	1.10	1.1	-	Y
8	Delos	EDL-08.0	72	9.9	20	1.0	67.5	1.05	1.5	-	Y
7	Nagler 6	EN6-07.0	82	9.7	12	0.5	77.1	1.03	1.3	7	Y*
4.7	Ethos SX	ETH-04.7	110	8.9	15	1.3	114.9	0.95	0.9	-	Y
5.5	Nagler 7	EN7-05.5	82	8.1	19	1.3	98.2	0.86	1.0	-	Y
6	Delos	EDL-06.0	72	7.6	20	1.0	90.0	0.81	1.1	-	Y
7	DeLite	EDE-07.0	62	7.5	20	0.5	77.1	0.80	1.3	-	Y
3.7	Ethos SX	ETH-03.7	110	7.0	15	1.1	145.9	0.75	0.7	-	Y
5	Nagler 6	EN6-05.0	82	7.0	12	0.5	108.0	0.74	0.9	7	Y*
8	Plössl	EAP-08.0	50	6.5	6	0.1	67.5	0.69	1.5	4	N
4.5	Delos	EDL-04.5	72	5.6	20	1.1	120.0	0.59	0.8	-	Y
5	DeLite	EDE-05.0	62	5.3	20	0.5	108.0	0.56	0.9	-	Y
3.5	Nagler 6	EN6-03.5	82	4.8	12	0.5	154.3	0.51	0.7	7	Y*
3.5	Delos	EDL-03.5	72	4.4	20	1.1	154.3	0.47	0.7	-	Y
4	DeLite	EDE-04.0	62	4.3	20	0.5	135.0	0.46	0.7	-	Y
3	DeLite	EDE-03.0	62	3.2	20	0.5	180.0	0.34	0.6	-	Y
1¼" Zoom Eyepieces for Medium and Higher Powers											
6-3	Nagler Zoom	ENZ-0306	50	5.1-2.6	10	0.3	90.0-180.0	0.54-0.28	1.1-0.6	5	N

NOTE: True Field in degrees = (Field Stop dia./Telescope Focal Length) X 57.3°

*Indicates additional Dioptrx Adapter required

†55mm Plössl requires 2" Eyepiece Barrel Extender (product code EBX-2120) or pull out from diagonal to reach focus. The large exit pupil will dim the image compared to other offerings with 2" barrels.